

Horticulture

Circulation Pumps

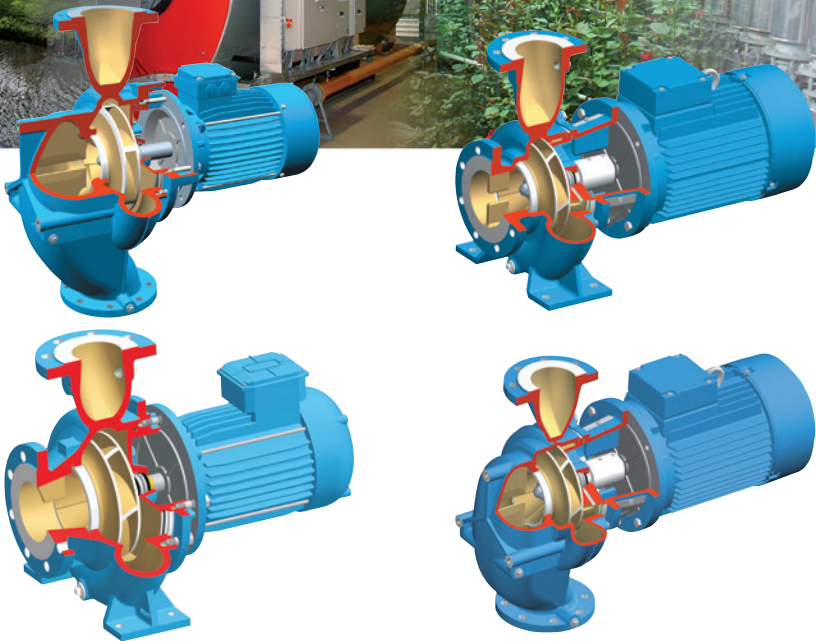

Pump applications in Horticulture Greenhouses

More than a century ago greenhouse horticulture activities started in the "Westland" area in the Netherlands. Over the years in this region a specialised infrastructure arose, uniting growers, trade channels and suppliers of greenhouse components.

During the last decades extensive research and constant innovation lead to the introduction of more and more technological systems in the greenhouse.

These developments turned greenhouse activities into a high-tech technology that nowadays is exported worldwide. This technology includes the pump circulation systems and related control systems.

Due to its highly specialised infrastructure the "Westland" area always remained a key factor in the supply chain of greenhouse technology. Many leading companies of greenhouse systems and components are Westland based. One of them is SPX Flow Technology.

By adopting state-of-the-art technology and constant focusing on client demands SPX FLOW is able to follow the technological developments in and around the greenhouse rapidly and adequately.

Circulation pumps

Thanks to this technological approach the growing conditions in the greenhouse can be accurately controlled and managed. One of the key factors for obtaining optimal growing conditions is efficient temperature control. The reliable performance of the circulation pumps is of paramount importance to this process. Another key factor is low energy consumption of the used equipment.

SPX FLOW's Johnson Pump circulation pumps combine the highest reliability with optimal efficiency, making it by far the most suitable pump for both heating and cooling systems.

Depending on the ambient temperature and the selected growing program the heat demand in the greenhouse may vary considerably. Due to smart solutions, like continuous flow control, the present systems are able to constantly adapt themselves to these varying conditions.

Flow control can be obtained by adopting frequency controlled motors on the circulation pumps. This requires a versatile performance of the pumps and the capacity to operate smoothly at different speeds and different duty points.

SPX FLOW supplies a range of low-speed circulation pumps, available as in-line pumps or as close-coupled monobloc pumps.



Pump types

The Horticulture circulation pumps comprise the following range:

CombiLine (CL)

CombiLine (CL) and CombiLineBloc (CLB) pumps are build-in in-line pumps. These pumps are easy to install in straight pipelines; inlet and outlet flange connections have the same size and pattern and are positioned in-line.

CL and CBH share the same impeller/shaft seal/drive section (Back-Pull-Out unit). For this design the electric motor is provided with an extended, stainless steel motor shaft. The impeller is mounted directly onto the motor shaft.

CLB and CB also share the same Back-Pull-Out unit. In this design the pump is assembled with a standard IEC flange motor with a stub shaft fitted onto the motor shaft. The electric motor is mounted to the pump cover by means of a lantern piece.

CombiLineBloc (CLB)

CombiBlocHorti (CBH) CombiBloc (CB)

CombiBlocHorti (CBH) and CombiBloc (CB) are close coupled foot-mounted volute pumps. These pumps are characterised by a compact build and a pump casing with horizontal inlet and vertical outlet.

All pump types are fitted with a rubber bellows mechanical seal, according to EN 12756 (DIN 24960).

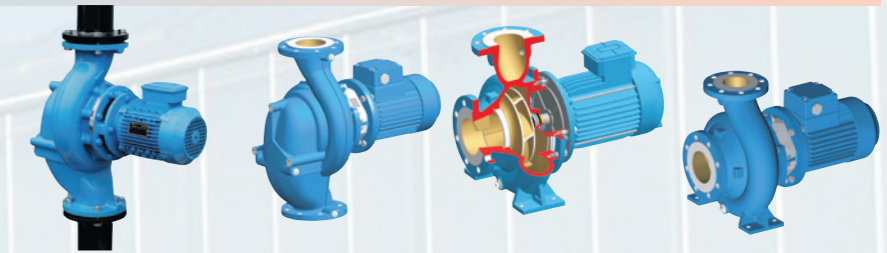

Technical specifications

		CL / CLB	CBH / CB
Maximum capacity	50 Hz:	400 m³/h	600 m³/h
	60 Hz:	500 m³/h	800 m³/h
Delivery head	50 Hz:	1 - 28 m	1 - 35 m
	60 Hz:	2 - 40 m	2 - 50 m
Maximum temperature		140 °C	140 °C
Maximum working pressure		6 bar (ND6)	10 bar (ND10)
		10 bar (ND10)	
Materials	pump casing	EN-GJL-250 (GG25)	EN-GJL-250 (GG25)
	impeller	EN-GJL-200 (GG20)	EN-GJL-200 (GG20)
	motor shaft	X17CrNi 16-2 (1.4057)	X17CrNi 16-2 (1.4057)
	stub shaft	X2CrNiMo17.12.2 (1.4404)	X2CrNiMo17.12.2 (1.4404)
	shaft sleeve	G-CuSn7ZnPb (Rg 7)	G-CuSn7ZnPb (Rg 7)
Nominal motor speed		1450 min ⁻¹ , 50 Hz 4 poles	
		950 min ⁻¹ , 50 Hz 6 poles	
		1750 min ⁻¹ , 60 Hz 4 poles	
		1150 min ⁻¹ , 60 Hz 6 poles	
Frequency control wall mounted		from 1.1 kW, range 10 to 60 Hz	
Electric motor protection class		IP55	
Electric motor voltage		230/400 V (≤ 1.5 kW), 50 Hz	
		400/695 V (≥ 2.2 kW), 50 Hz	
		277/480 V (≤ 1.5 kW), 60 Hz	
		480/830 V (≥ 2.2 kW), 60 Hz	
		other voltages/speeds on request	
Mechanical seal		EN 12756 (DIN 24960), AQ1EGG carbon/silicon carbide, EPDM bellows	

Design features

BACK-PULL-OUT UNITS

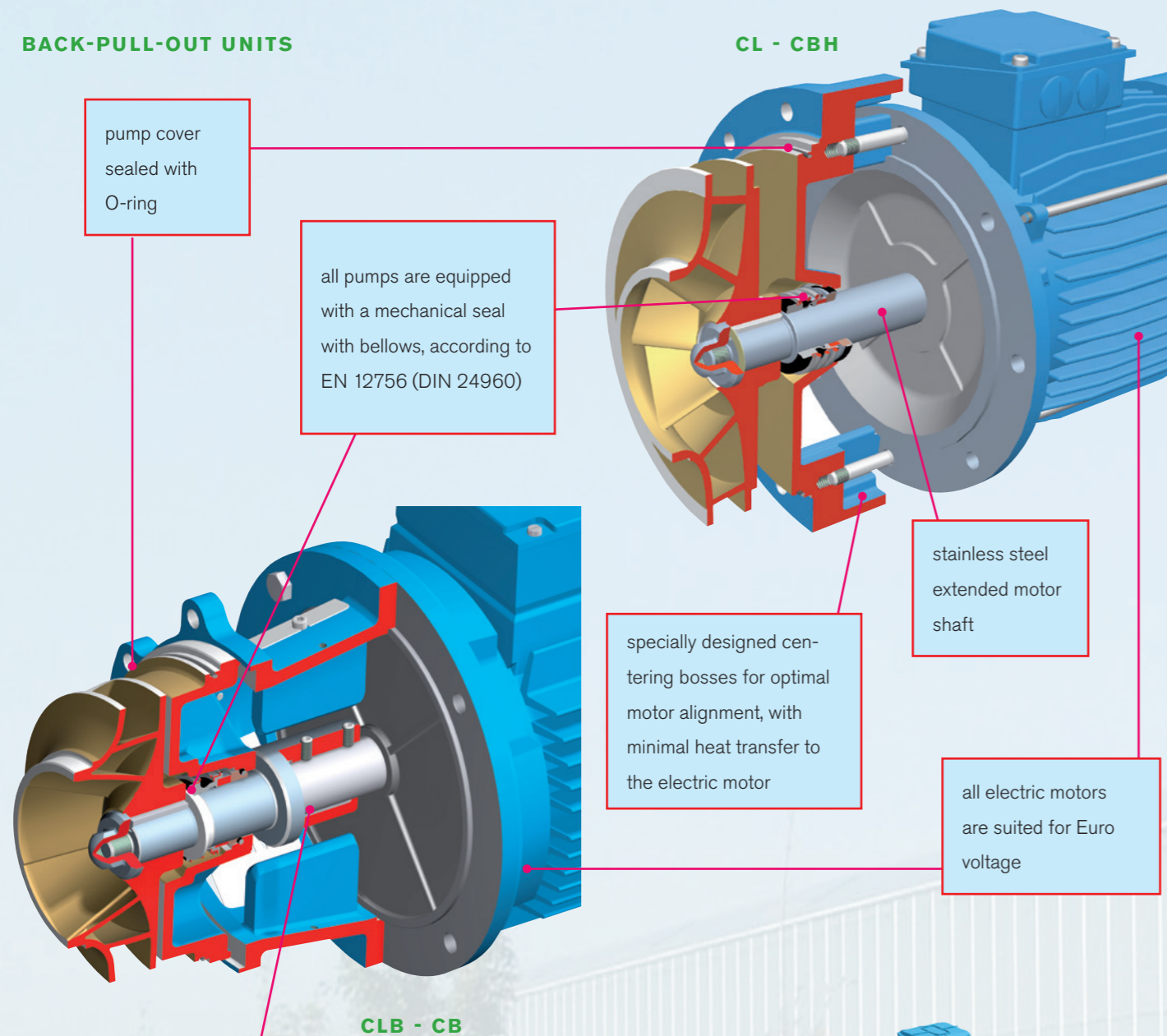

Design features

PUMP CASINGS

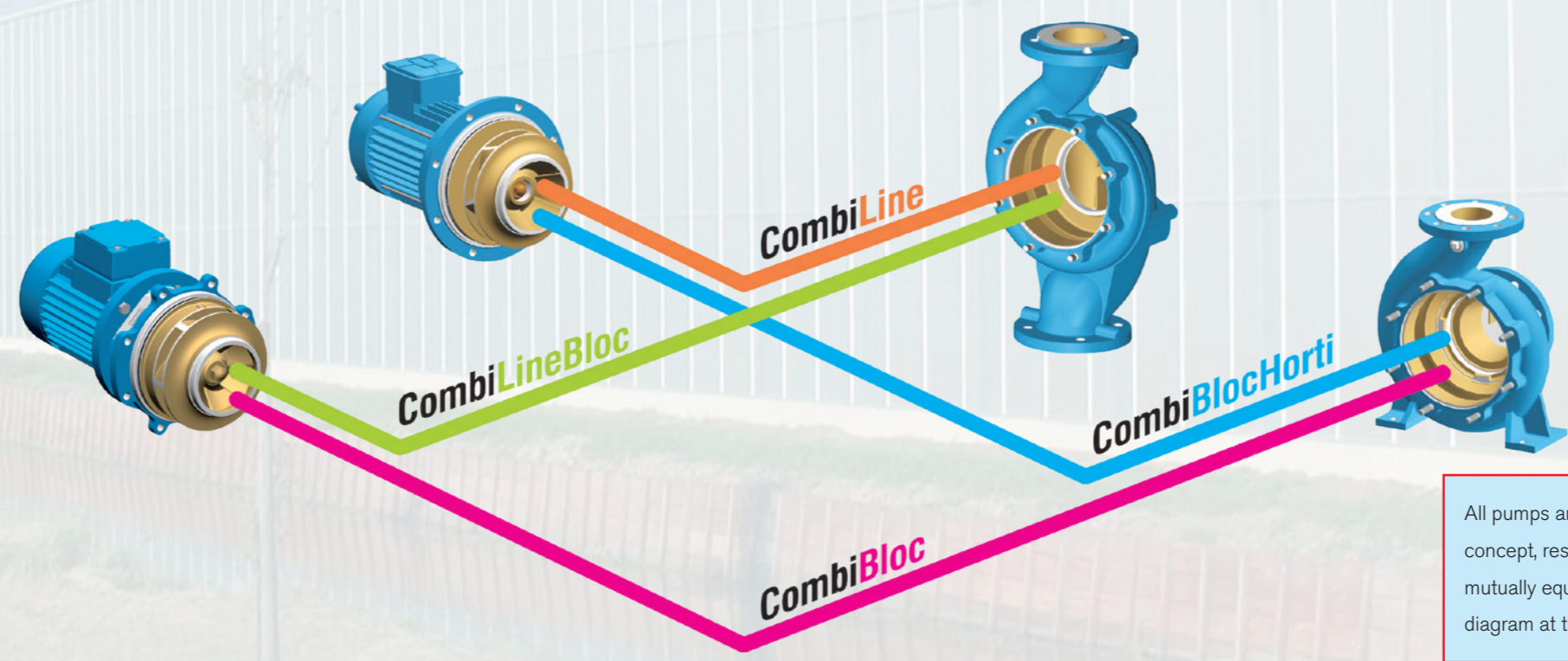
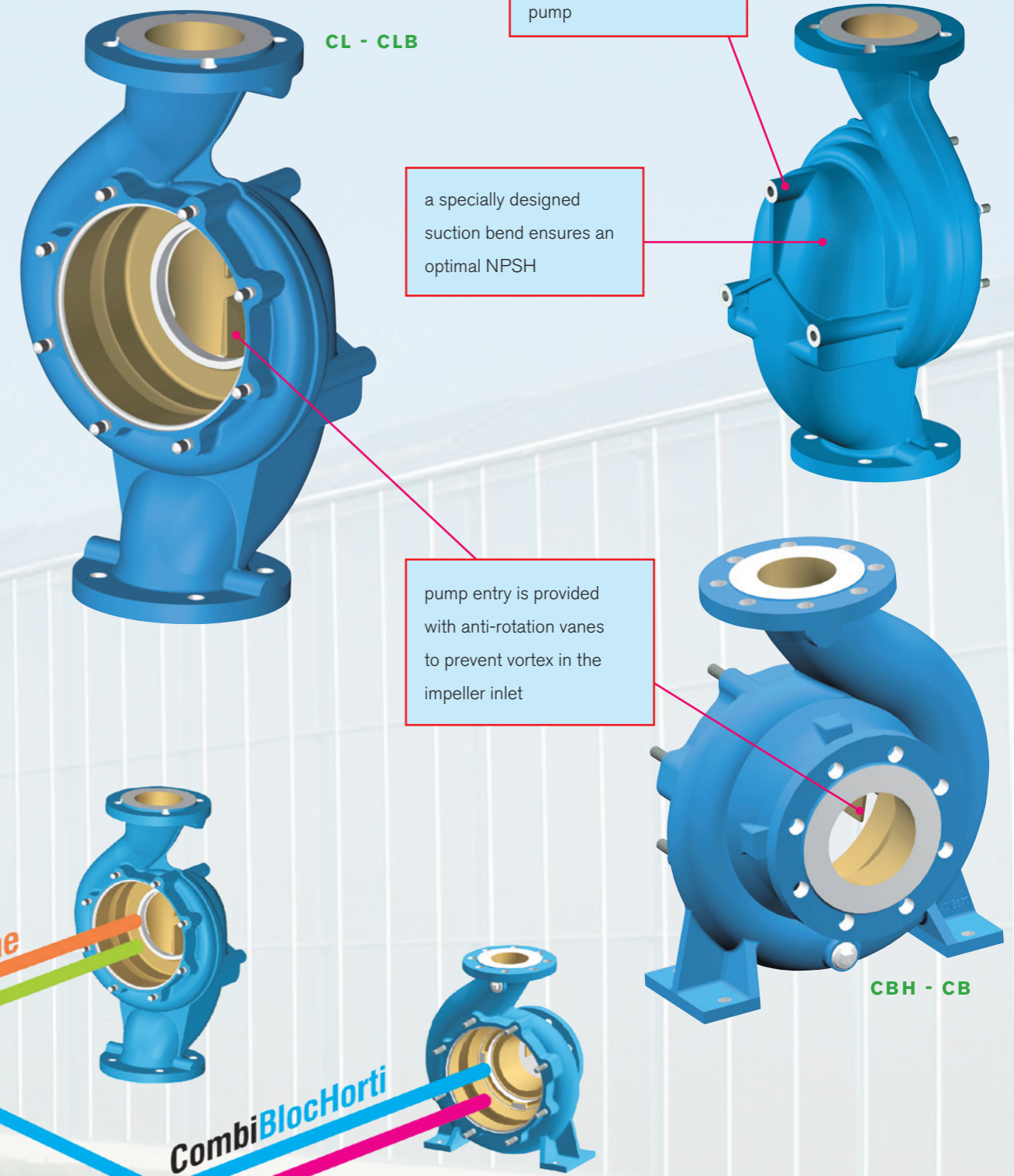

The hydraulic parts of all pump types have been optimized by using CFD (Computational Fluid Dynamics) during the design stage of the pump. Extensive testing at the SPX FLOW test laboratories proved that the pumps amply meet their design specifications.

All pumps are designed according to a strong modular concept, resulting in a high degree of interchangeability of mutually equal components between the pump families (see diagram at the left).

Pump configurations

The following overview shows the possible pump configurations of the Horticulture pump range.

COMBILINE

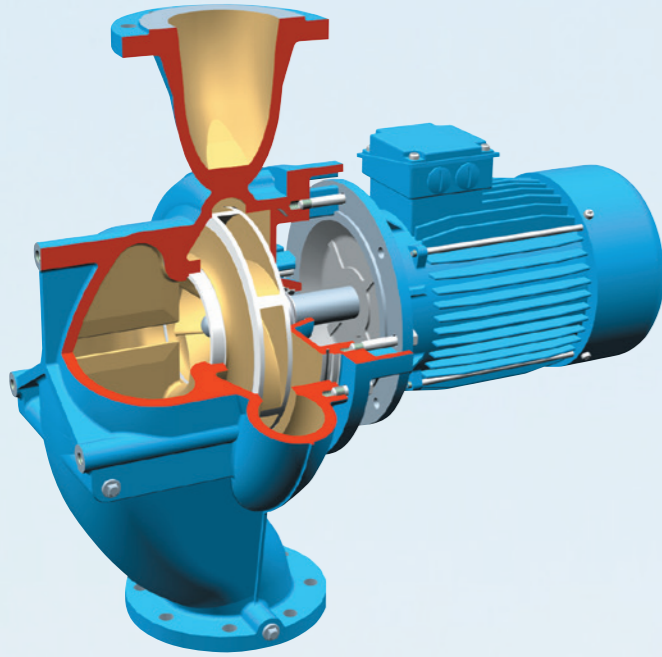

COMBIBLOCHORTI

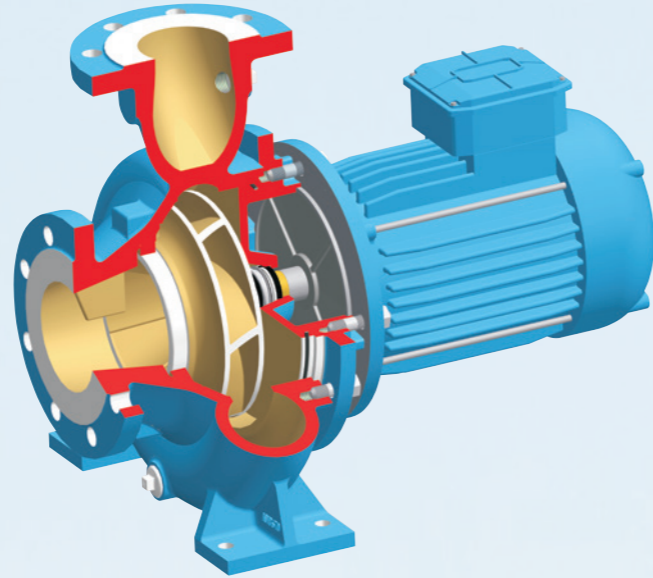

COMBILINEBLOC

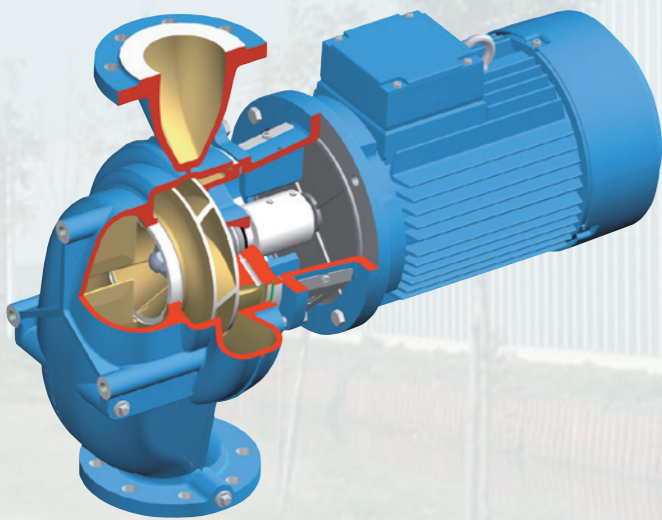

COMBIBLOC

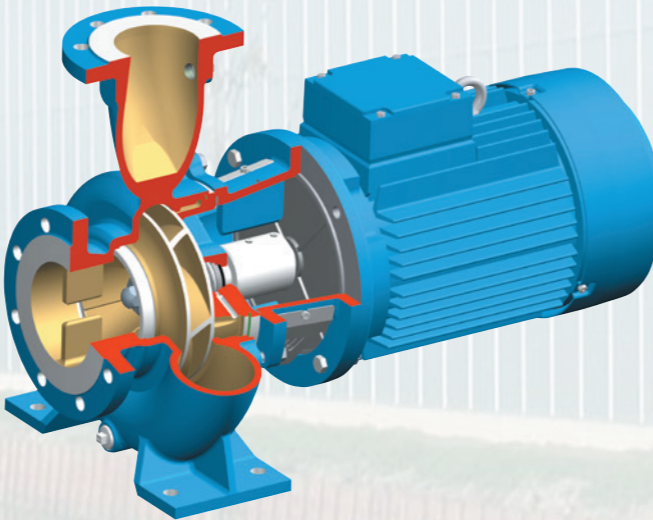

Pump mounting positions

It is possible to mount the pump in several different positions between the lines of the system, in horizontal as well as in vertical position. However, not all the possible positions are allowed. This overview shows the allowed mounting positions of the pumps of the Horticulture range.

Horizontal, with motor in horizontal position, connecting box on top.

CL
CLB
CBH
CB

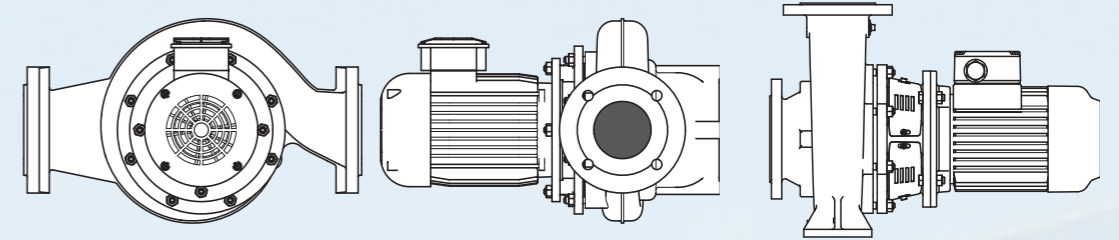

Vertical, with motor in horizontal position, connecting box on top.

CL
CLB

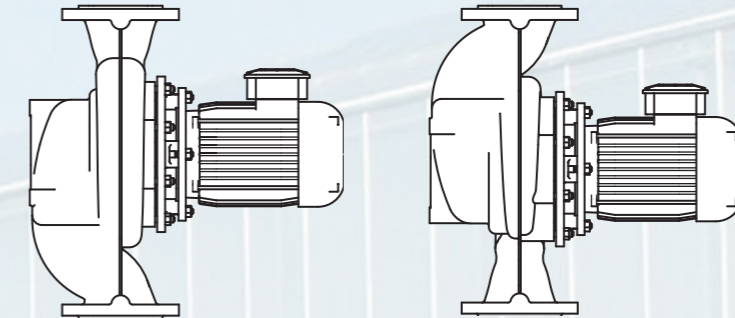

Horizontal, with motor in vertical position. If necessary, the pump can be mounted on a base plate and foundation to avoid pump loads to the pipe work in case of large weighty pump types.

CL
CLB
CBH
CB

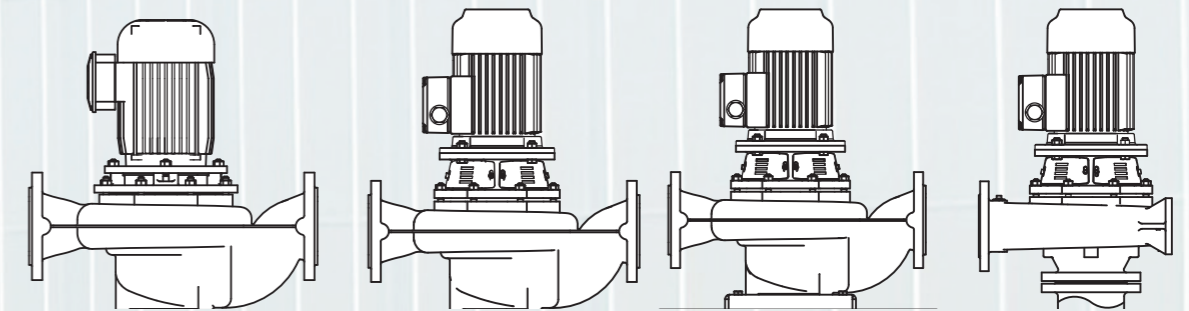

The following mounting configurations are **not allowed**:

CL
CLB
CBH
CB

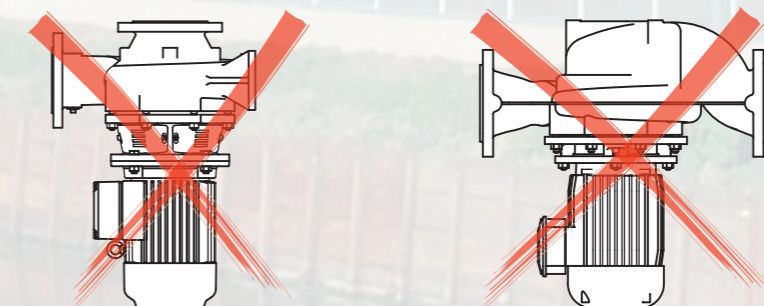

Performance curves

In-line pumps CL and CLB



These performance curves are based on standard electric motor speeds and refer to water with a temperature of 20 °C.

CL 50Hz - 4 poles

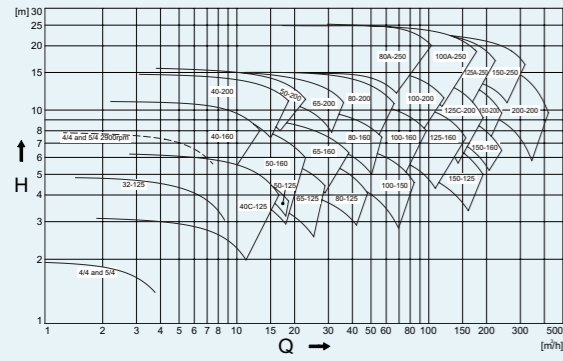

CL 50Hz - 6 poles

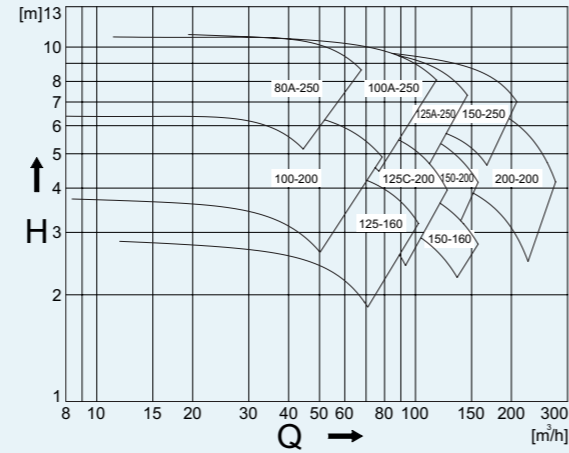

CL 60Hz - 4 poles

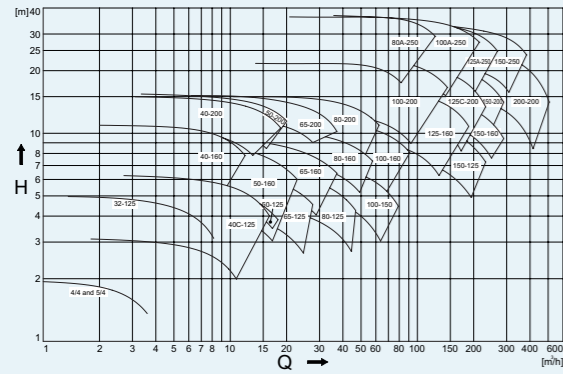

CL 60Hz - 6 poles

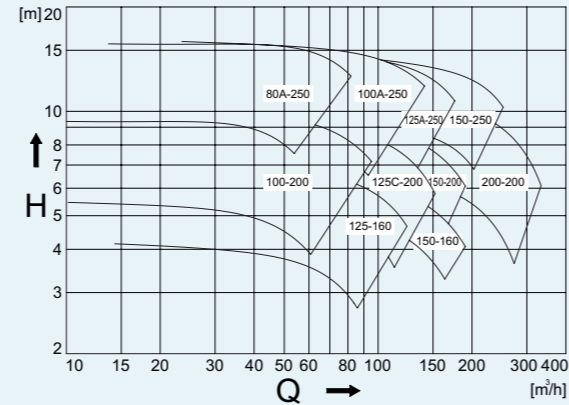

CLB 50Hz - 4 poles

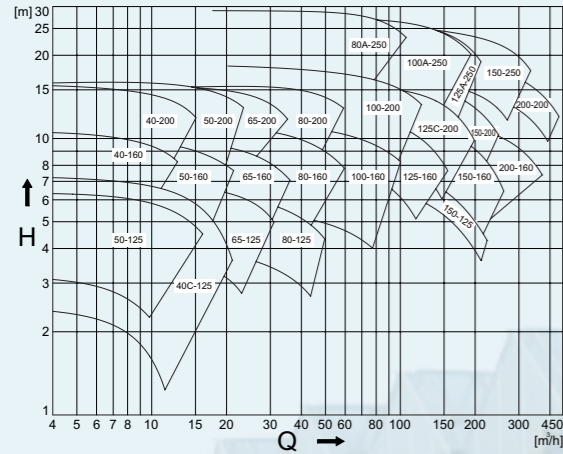

CLB 50Hz - 6 poles

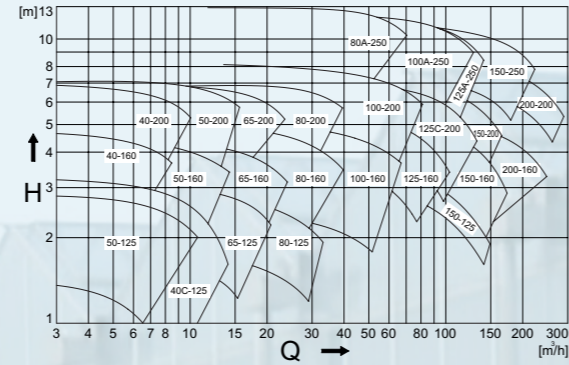

CLB 60Hz - 4 poles

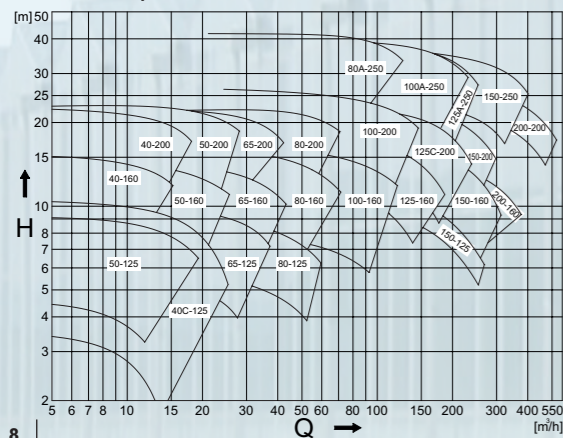

CLB 60Hz - 6 poles

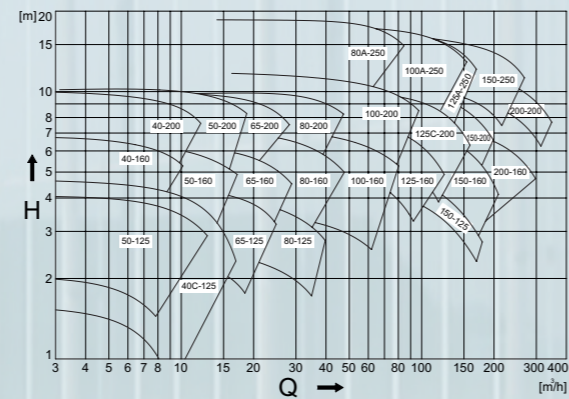

Performance curves

Monobloc pumps CBH and CB

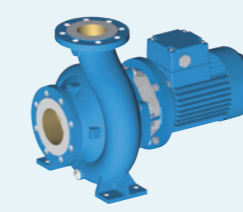

These performance curves are based on standard electric motor speeds and refer to water with a temperature of 20 °C.

CBH 50Hz - 4 poles

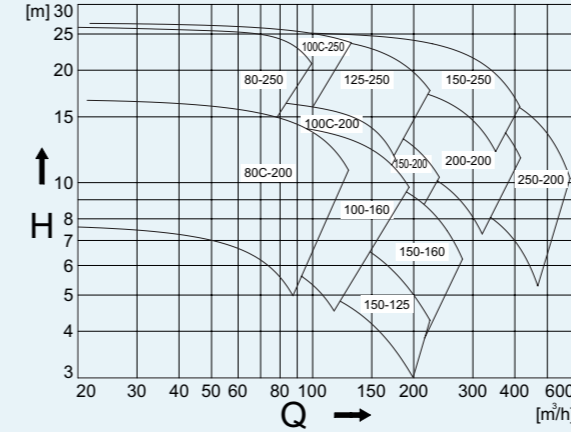

CBH 50Hz - 6 poles

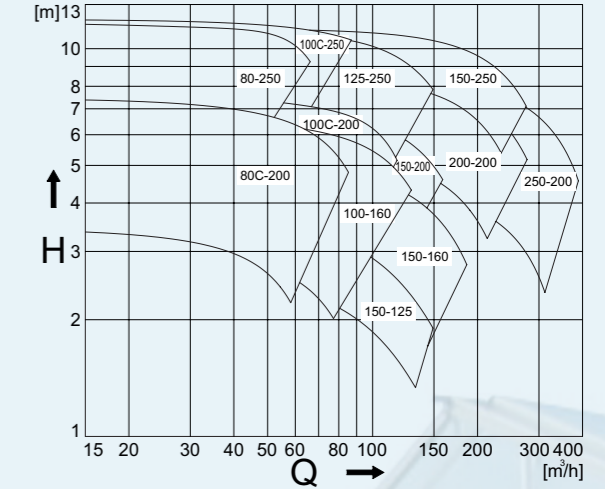

CBH 60Hz - 4 poles

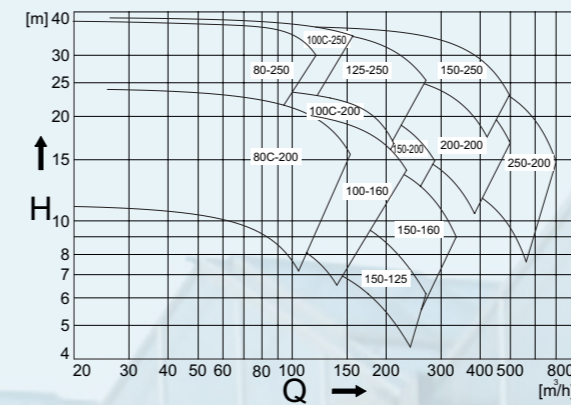

CBH 60Hz - 6 poles

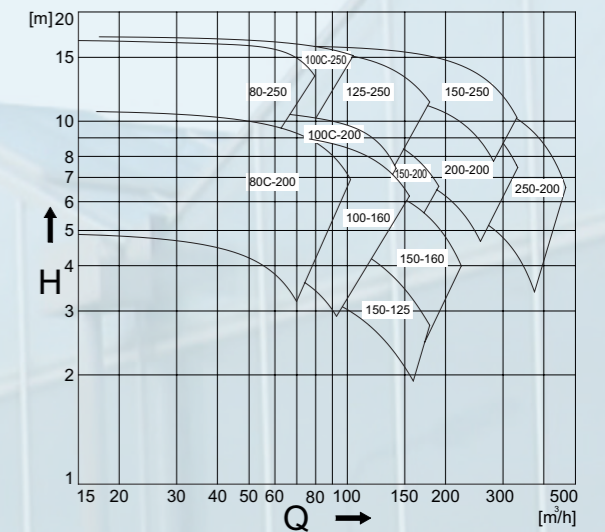

CB 50Hz - 4 poles

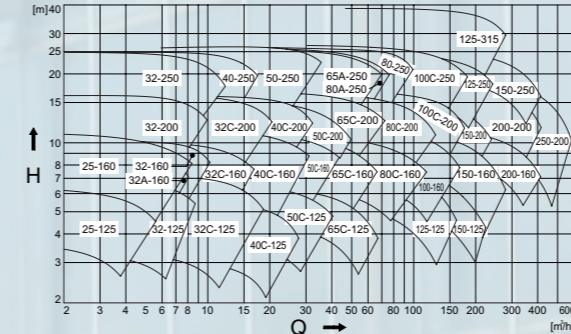

CB 50Hz - 6 poles

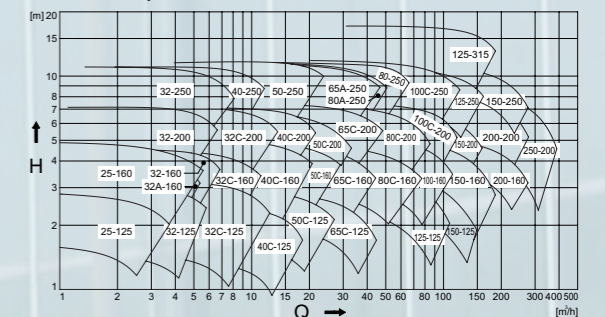

CB 60Hz - 4 poles

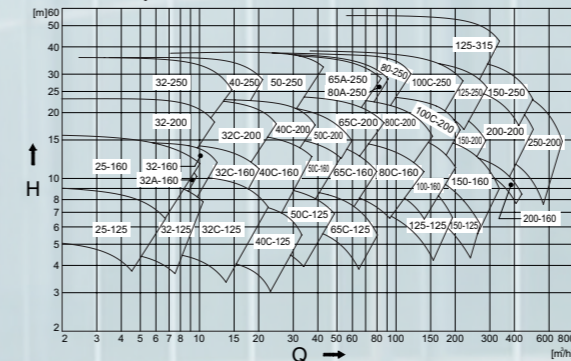

CB 60Hz - 6 poles

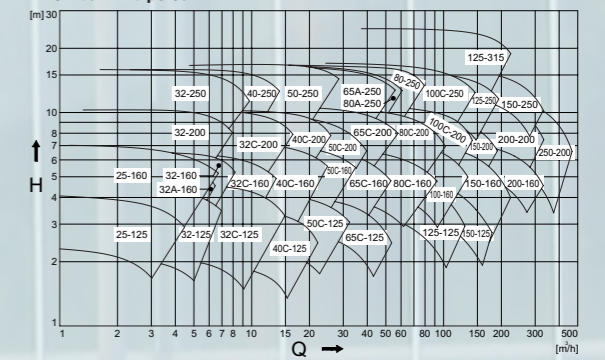

Circulation systems

HEATED WATER CIRCULATION

Water circulation systems in the greenhouse are heated by a boiler or by heated water buffered in a large tank. The burner of the boiler also supplies the CO₂ gas for growth; in those situations the heat is stored in the buffer tank. The heat might also be delivered by external companies, for example a joint facility for total energy supply in greenhouse areas. The heat is delivered to the circulation system by means of a heat exchanger.

A manifold unit and a related control management system distributes the heat to all sections in the greenhouse.

1. **Boiler with burner**
2. **Power / heating unit**
3. **Buffer tank**
4. **Manifold unit with circulation pumps**
5. **External supply of heat**
6. **Heat exchanger**
7. **System pressure unit**
8. **Exhaust gas cleaning unit**
9. **Cultivated plants area**

POWER / HEATING UNIT

A power / heating unit usually consists of a combustion engine running on natural gas and a generator for delivery of electricity. The electricity is used for illumination of the crop, CO₂ gasses from the burner are lead into the greenhouse for growth of the crop and the heat is used for heating the greenhouse or is temporarily stored in the buffer tank.

Power / heating units are also applied to compensate peak loads in the electricity supply. In these cases the produced electrical power is supplied to the public electricity grid.

This is a welcome economical benefit for the greenhouse owner, in this way reducing the operational costs of greenhouse exploitation.

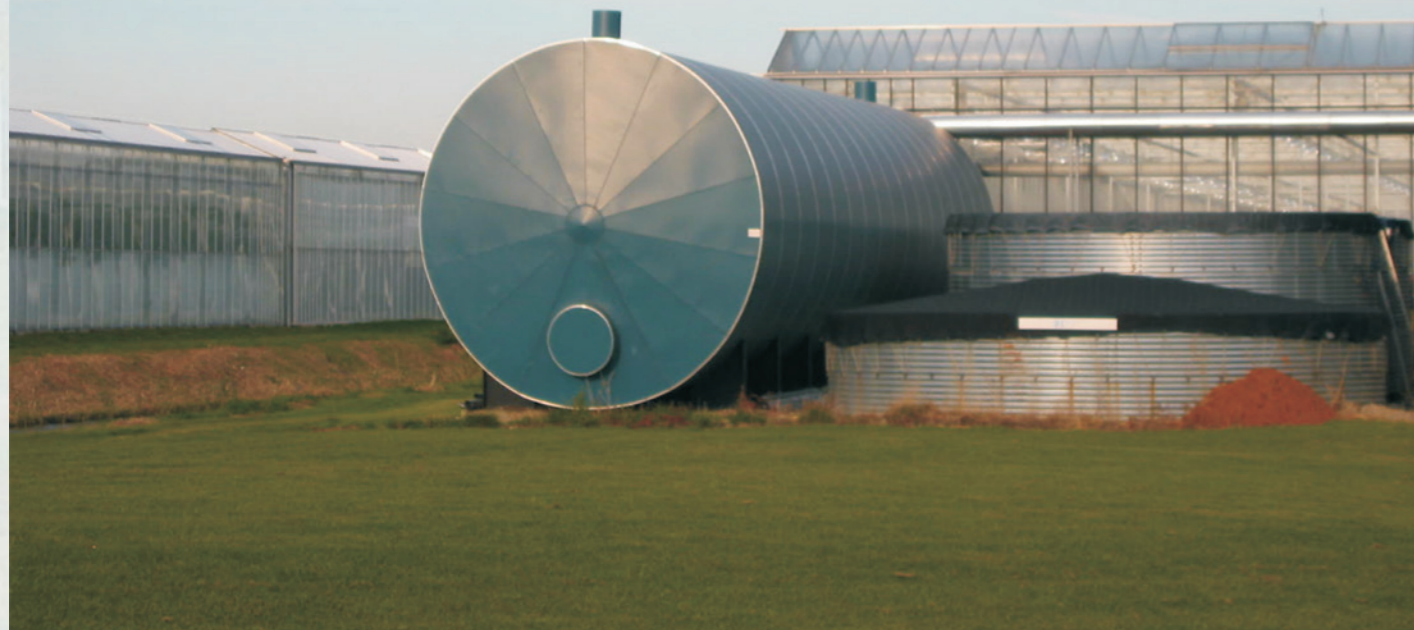
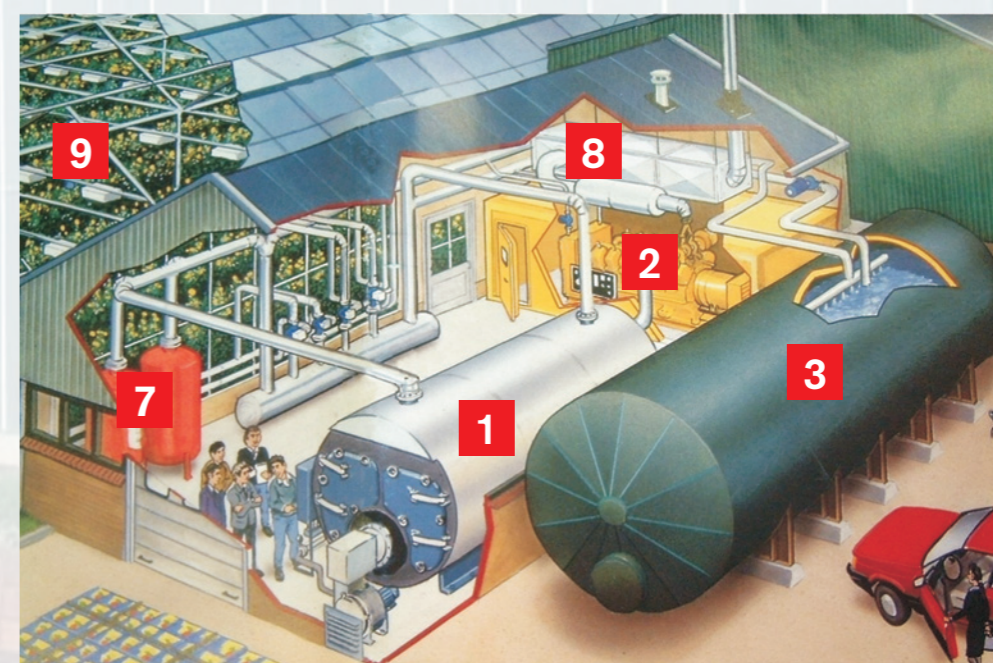
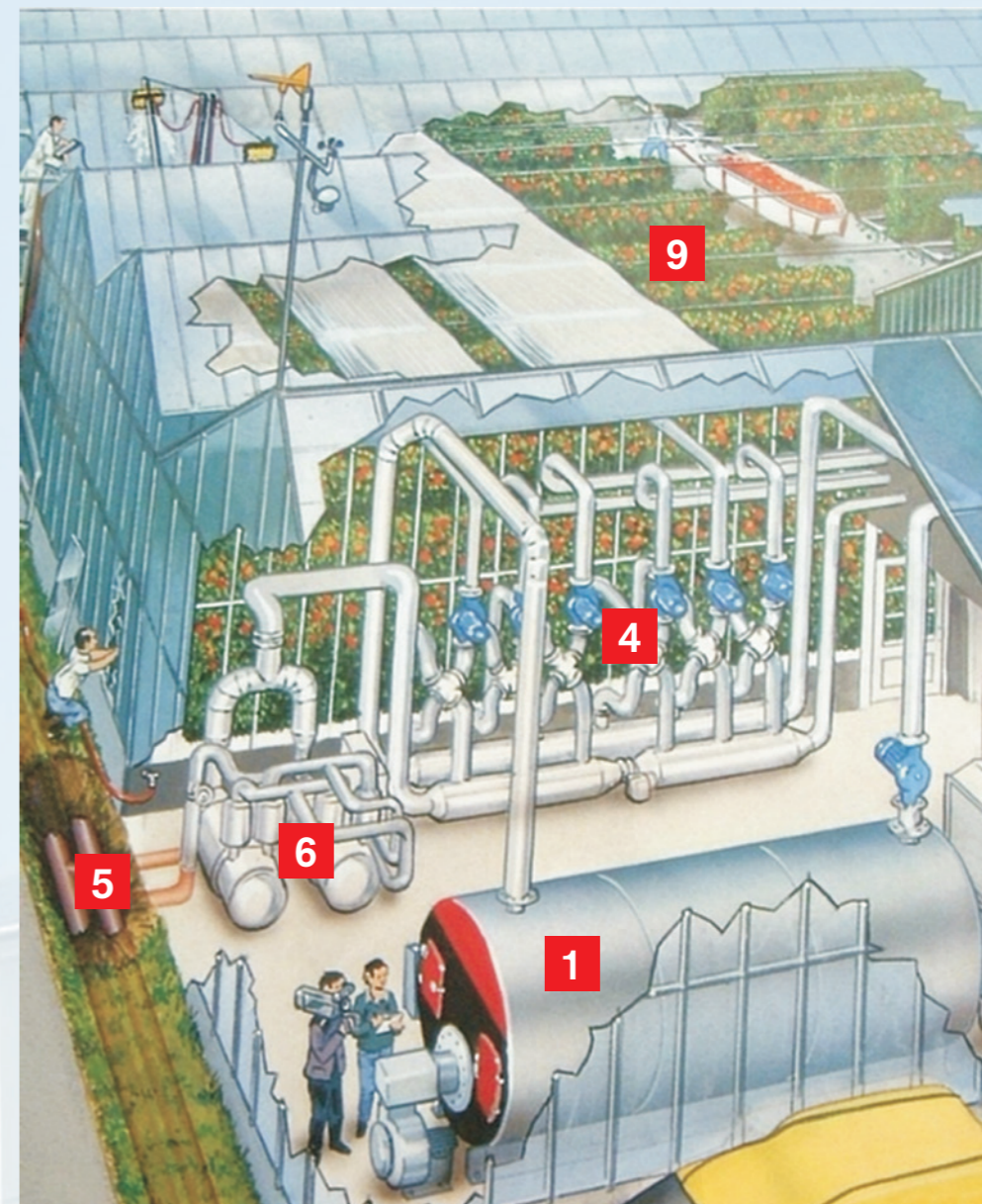

Frequency controlled motor drives

In a unique cooperation with Danfoss, SPX FLOW can supply pumps with frequency controlled motor drive. In this way world wide service expertise and "online" support are guaranteed.



VLT® HVAC DRIVE FC 102

It offers a vast number of pump-specific features developed in cooperation with OEMs, contractors and manufactures all over the world. The VLT® HVAC Drive FC 102, built on Danfoss' new modular plug-and-play platform and dedicated to HVAC applications, makes HVAC operation easy. Operators, equipment and control systems all communicate effortlessly with the VLT® HVAC Drive FC 102.

27 Display languages are available.

The Local Control Panel (LCP) constantly improves on the intuitive man-machine interface.

Automatic Motor Adoption and Automatic Energy Optimisation support fast commissioning.

Due to a series of self-protecting and monitoring features and a highly durable mechanical design, the VLT® HVAC Drive FC 102 is practically maintenance free.

- From 1.1 kW
- Enclosures IP20/chassis, IP21/NEMA 1 & IP55/NEMA12
- Modular plug-and-play platform
- Ambient temperature up to 50 °C
- Automatic Motor Adoption and Automatic Energy Optimisation
- Built-in RFI filter ensures compliance with EMC directives
- Hot-pluggable Local Control Panel (LCP)

LOCAL CONTROL PANEL (LCP)

GRAPHICAL DISPLAY

- International characters and signs
- Showing bars and graphs
- Possible to select 27 languages

MENU STRUCTURE

- Easy shortcut for the experienced user
- Edit and operate in different set-ups simultaneously

QUICK MENUS

- a Danfoss defined Quick Menu
- a Personal defined Quick Menu
- a Changes Made Menu list the parameters unique for your application
- a function Setup Menu provides quick and easy setup for specific applications
- a Logging Menu provides access to operation history

OTHER BENEFITS

- Removable during operation
- Up- and download functionality
- IP65 rating when mounted in a panel door
- Numerical version also available
- Important buttons are now illuminated when active

Hydraulic Investigator

To find the best fitting pump for your pump application in the greenhouse the CombiLine, CombiLineBloc, CombiBlocHorti or CombiBloc ranges are available in a large number of sizes, which covers an ample hydraulic field.

We recommend using our Pump Selection software "Hydraulic Investigator" developed by SPX Flow Technology Assen, to select the best available pump for your particular application.

FREQUENCY CONTROL

Pumps with fixed speed motors must be selected with the capacity to handle possible peak loads during extreme conditions. This implicates that most of the time the pump will be operating at very unfavorable efficiency conditions, resulting in an unnecessarily high energy consumption.

Frequency controlled electric motors save a large amount of energy by adjusting the motor speed according to the actual temperature measured in the greenhouse.

During extreme weather conditions frequency controlled motor drives can rev up the pumps to enable them to satisfy to the increased heat demand in the greenhouse sections.

Reducing the motor speed of a centrifugal pump by 20% corresponds to a 20% reduction in flow, whereas the energy consumption will be reduced by as much as 50%. On yearly basis a substantial reduction in energy costs can be obtained.

- Guided pump selection based upon specific needs for any pump application.
- Capacity, delivery head, mains frequency 50 or 60Hz and other criteria can be used to select the best possible pumps for entire systems.
- Simulation of variable speed operation, with direct read-out of reduction of power consumption.
- Compare alternative solutions.
- Selection parameters are saved to consult later on or to manipulate afterwards.
- Substantial reduction of energy costs.

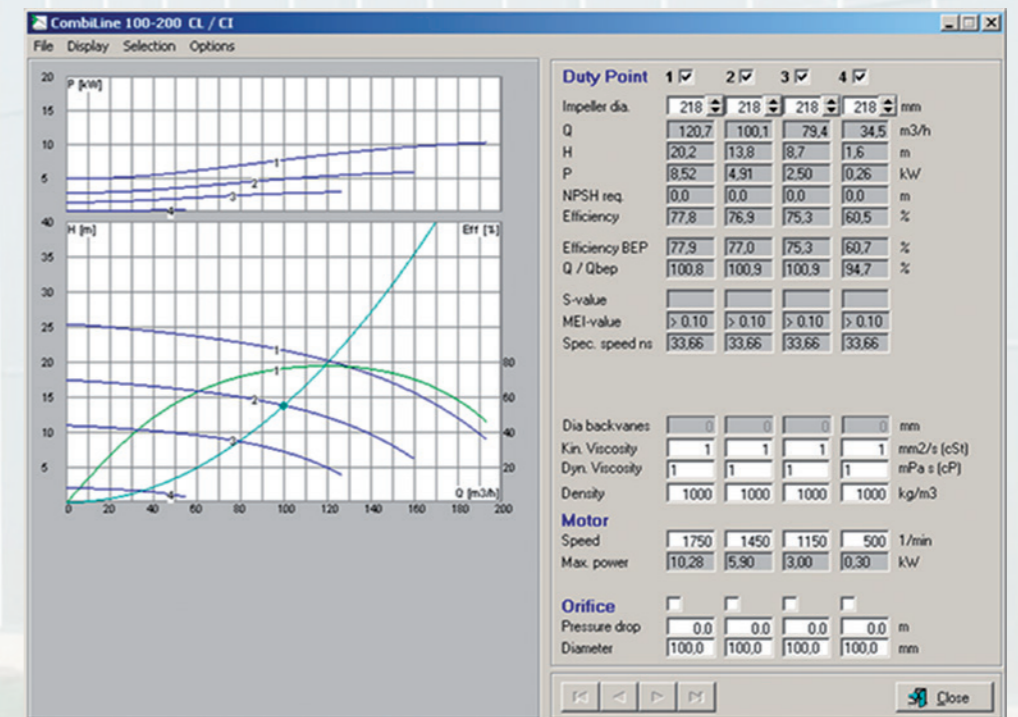
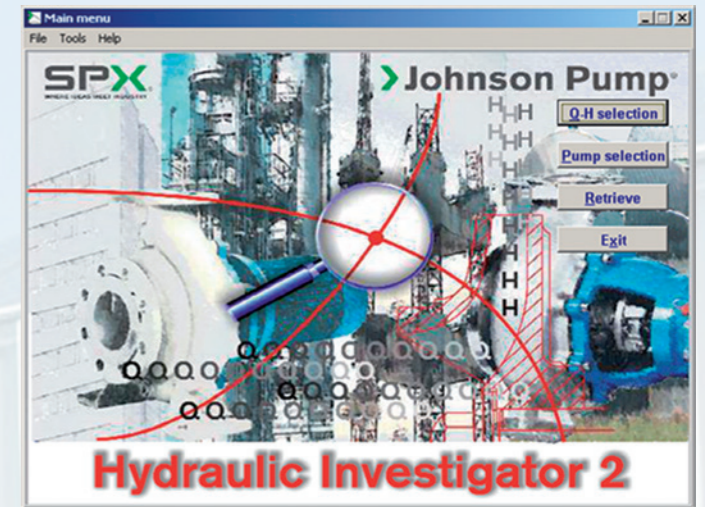

Example: CL 100-200 with 7.5 kW motor 50 Hz (8.6 kW at 60 Hz).

Capacity normal duty 100 m³/h, power consumption 4.91 kW, speed 1450 min⁻¹, 50 Hz.

Peak load 120 m³/h, power consumption 8.52 kW, speed 1750 min⁻¹, 60 Hz.

Off load duty 80 m³/h, power consumption 2.50 kW, speed 1150 min⁻¹.



SPX FLOW EUROPE LTD - THE NETHERLANDS
SALES OFFICE HORTICULTURE

De Hondert Margen 23
2678 AC De Lier
The Netherlands
TEL +31 (0)174 518 410
EMAIL: ft.horticulture.nl@spxflow.com
www.spxflow.com/johnson-pump/segments/horticulture

Exclusive Agent in China
CHANGZHOU TOP GREENHOUSE CO.,LTD

No.309 Huanglianshu, Jinfeng, Hengshanqiao, Wujin
District, Changzhou, Jiangsu, China
Tel: +86 0519 88993008
E-mail : sales01@topgreenhousetech.com
www.topgreenhousetech.com

SPX FLOW, Inc. reserves the right to incorporate our latest design and material changes without notice or obligation.

Design features, materials of construction and dimensional data, as described in this bulletin, are provided for your information only and should not be relied upon unless confirmed in writing. Please contact your local sales representative for product availability in your region. For more information visit www.spxflow.com.
The green "X" and "X" are trademarks of SPX FLOW, Inc.